

040-0700 Lift and Latch Handle



This new product is designed to operate on back hoe loader and excavator vertical opening windows for full unobstructed vision. Latching is provided in the 'fully open' or overhead position, and in the 'closed' front latched position. This integrated latching and handle solution features full gloved hand clearance, one-touch action release and slam action retention providing safe and secure operation.

DESIGNED FOR:

- Medium to heavy-duty on-highway vehicle vertical windows where movement up and over is desired

Global Locations:

TriMark Corporation
500 Bailey Avenue
P.O. Box 350
New Hampton, Iowa 50659
United States
Tel: 641-394-3188
Fax: 641-394-2392
1-800-447-0343
www.trimarkcorp.com

TriMark Europe
Cedar Court
Walker road
Bardon Hill
Coalville LE67 1TU
United Kingdom
Tel: +44(0)1530 512460
Fax: +44(0)1530 512461
www.trimarkeu.com

TriMark (Xuzhou)
Building A5 Jingwu Road
Xuzhou Economic
Development Zone
Xuzhou, Jiangsu
221004 PR China
Tel: +86 516 8773 0018
Fax: +86 516 8773 0058
www.trimarkcn.com



TriMark. Interactive. Product. Selector



TriMark



TriMark Corporation

FEATURES/BENEFITS:

- Easy to operate (ergonomics), operator handle is gas injected which gives automotive feel and appearance
- 12mm (.47") plunger travel provides secure engagement into window tracks
- Right and left hand configuration is sold as a pair
- Manufactured in injection molded engineered plastic to save weight
- Lower cost compared to zinc die cast versions

INSTALLATION:

- Push button handle with 195mm (7.68") mounting pattern — retrofits with some European up and over handles
- Installs easily with (4) M6 mounting fasteners (not included)

MATERIAL:

- Handle/Plunger: Glass reinforced nylon

Individual part dimensions are for reference only. Refer to individual part drawings for complete dimensions, specifications, and installation procedures. Engineering assistance and application drawings are available.

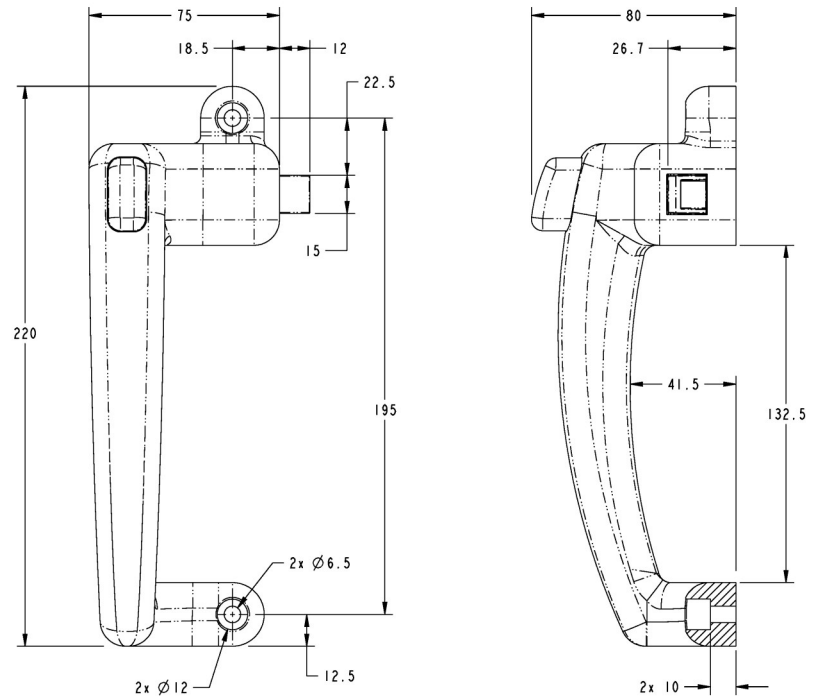

For more information visit
www.trimarkcorp.com

